

Rolling Service Door Systems



Product Line

SERIES

600 610 620 625



INDUSTRY LEADING
COMMERCIAL & INDUSTRIAL SOLUTIONS

Rolling Service Doors

THE TURNKEY SOURCE FOR COMMERCIAL AND INDUSTRIAL SOLUTIONS AND SERVICE

Selection of Overhead Door products automatically includes the unequalled expertise and experience of Overhead Door Red Ribbon Distributors. Nationwide coverage by our over 400 Red Ribbon Distributors is unique in our industry—providing a single source for design and application consulting, installation, service and ongoing maintenance. Turnkey services to maximize the lasting value of your product choice. Your Overhead Door Distributor is also your only source for a full line of commercial and industrial door and operator systems



specifically designed for integrated applications. For over four generations, our Red Ribbon Distributors have been committed to providing commercial and industrial door solutions. Combined with Overhead Door product design and manufacturing superiority, our distributors are a proud part of the Overhead Door family, sharing our name, our Ribbon logo and our commitment to industry leading innovation and excellence.

GENERAL FEATURES & BENEFITS

A Comprehensive Line of Rolling Service Doors

- Galvanized steel, stainless steel and aluminum doors in a variety of gauges, slat profiles, finishes and options
- Standard door widths up to 30' (9144 mm) and 28' (8534 mm) in height, and custom door sizes up to 1500 sq. ft. (139,355 sq.mm)
- Rolling service doors for heavy-duty, medium-duty and light-duty applications
- Coil-Away™ 600 Series door offers an economical solution for openings to 16' wide and 16' high (4877 mm and 4877 mm)
- Stormtite™ 620 and Stormtite™ 625 Series insulated doors provide extra protection against the elements

Solid Construction for Reliable Operation Over the Long Term

- Solid construction withstands wind loading of 20 psf, with a higher wind load option to meet specifications
- Guide designed to ensure smooth curtain operation
- Steel brackets provide additional strength
- Helical torsion springs designed for 20,000 cycles, with high usage option to 100,000 cycles

Computer Designed for Precision Operation

- Each door is computer-designed to ensure precision manufacturing and facilitate installation
- Computer-matched door counterbalance system and optional motor operator promote precision operation and performance

A Host of Standard Features and Available Options

- Roll-formed galvanized steel, stainless steel or aluminum curtains in weights from 26 to 14 gauge (not all gauges available in all materials)
- Curved or flat slats in a range of sizes and profiles, including the C-600, a 6" (152 mm), 1 3/8" (35 mm) curved slat for heavy-duty applications
- Finishes include primed and painted steel, powder-coated paint finish in 215 premium colors or color-matched to specification, as well as clear or colored anodized aluminum
- Face of wall mounting is standard with between-jamb mounting available for medium- and heavy-duty doors
- Push-up, chain-hoist, crank or motor operation available
- Electric motor option with an array of radio and remote controls simplifies door operation
- Ventilated slats with perforations or fenestration extend applications to open-air environments (610 Series only)
- Weatherstripping (620 Series) and/or insulated slats (625 Series) offer additional protection against air infiltration
- High-usage package and pedestrian pass doors available for special applications



The breadth of Overhead Door Corporation's rolling service door product line ensures that your project specifications will be met with ease and style. Ideal for situations where sideroom and headroom are at a premium, our upward-coiling service doors fit openings up to 1500 sq. ft. (139,355 sq.mm) and are available with the industry's widest array of slat profiles, curtain materials and colors, offering a virtually endless array of options to satisfy both aesthetic considerations and working requirements.

Fabricated of interlocking steel, stainless steel or aluminum curtains in a variety of slat profiles, finishes and options, our doors are designed for durability, serviceability and good looks. Each of our rolling service doors is computer designed to your specifications, then solidly constructed to promote easy installation, trouble-free operation and long life. From the lightweight, economical 26-gauge Coil-Away™ door to the 14-gauge C-600 slat 610 Series door, our comprehensive system of rolling service doors covers the spectrum of commercial/industrial applications.

Installation and Service: Overhead Door Company of Huntsville



Rolling Service Door Selection Chart

Slat Data

A Variety of Profiles, Finishes, Materials and Options

Overhead Door Corporation offers a broad range of rolling service door curtains to satisfy any number of project requirements. Rolling service doors are available with a variety of slat profiles, materials, gauges and finishes.

Our rolling service doors feature a standard galvanized steel curtain, in a range of gauges to suit your project requirements. Steel slats are finished with a rust-inhibitive, roll-coating process that incorporates baked-on prime paint, and a baked-on polyester top coat of gray (standard) or tan (optional, but not available on C-600). An optional powder coat finish is available in 215 standard colors, or can be color matched to your specifications.

Aluminum and stainless steel slats are offered as options for 610, 620 and 625 Series doors. An array of finishes create an attractive and polished appearance for your rolling door closure. Stainless slats are manufactured with a No. 2b finish (standard) or No. 4 mill finish

(option). Aluminum slats are available with a mill finish (standard) clear-anodized finish (option) or bronze-anodized finish (option).

Slats for Special Applications

Our insulated Stormtite™ door features the F-265i slat, a CFC-free insulated slat that provides additional protection against air infiltration. For special, oversize, heavy-duty, non-insulated applications, we offer the C-600 slat — a 6" (152 mm), 1 3/8" (35 mm) curved slat.

The F-265 and C-275 slat profiles are also available with perforation or fenestration for applications where ventilation is required. Perforated slats feature 1/16" (2 mm) diameter holes on 3/32" (2 mm) centers, and are fabricated of 18 gauge galvanized steel with a durable, baked-on gray paint finish. Fenestrated slats feature uniformly spaced openings of 5/8" x 3" (16 mm x 76 mm) for air flow and light infiltration. Doors can be constructed entirely of perforated or fenestrated slats, or these special slats can be used selectively to provide air flow and light infiltration as required.

Up To 215 Standard Powder Coat Finishes

The Color Palette for Rolling Steel Products specifying from powder coat finishes in up to 215 colors is available from your Overhead Door distributor. Color may also be matched to architect's specifications to best compliment the look of the facility.



Rolling Service		GENERAL SPECIFICATIONS												
SERIES	Standard Maximum width	Standard Maximum height	Maximum size	Standard mounting		Standard operation		Curtain material		Slat profile type		Wind load	Insulated slats	Standard finish
				face of wall	chain	galv steel	ss/ alum	Standard	Optional	20 psf	•	primed paint		
Heavy Duty	625 Stormtite™ Insulated	30' (9144 mm)	28' (8534 mm)	900 sq ft (83,613 sq.mm)	face of wall	chain	galv steel	ss/ alum	F-265i		20 psf	•	primed paint	
	620 Stormtite™	30' (9144 mm)	28' (8534 mm)	900 sq ft (83,613 sq.mm)	face of wall	push up	galv steel	ss/ alum	F-265		20 psf		primed paint	
	610	30' (9144 mm)	28' (8534 mm)	900 sq ft (83,613 sq.mm)	face of wall	push up	galv steel	ss/ alum	C-187 C-275 F-265		20 psf		primed paint	
	610 C-600 Slat	65' (19812 mm)	30' (9144 mm)	1500 sq ft (139,355 sq.mm)	face of wall	motor	galv steel		C-600				primed paint	
Medium Duty	610 w/24 gauge	16' (4877 mm)	16' (4877 mm)	16' (23,560 sq.mm)	face of wall	push up	galv steel		C-187/ F-265		20 psf		primed paint	
Light Duty	600 Coil-Away™	16' (4877 mm)	16' (4877 mm)	256 sq ft (23,560 sq.mm)	face of wall	push up	galv steel		CAW		optional		primed paint	



C-187 Slat

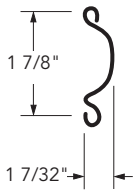

CAW Slat

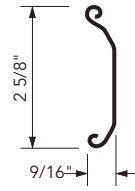

**F-265 Slat
FE-265 Slat**

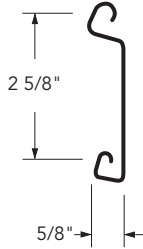

C-275 Slat

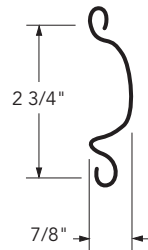

F-265i Slat

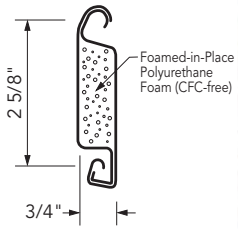

C-600 Slat

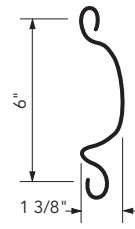

AVAILABLE OPTIONS

Color	Hood	Internal Hood Baffle	Lock	Electric operator	Curtain material			High-usage package	Pedestrian pass door	Exhaust ports	Weatherstripping			High-wind load package	Ventilated slats	Between-jamb mounting	Galvanized steel bottom bar	Stainless steel bracket	Cylinder lock
					Galvanized steel	Stainless steel	Aluminum				Bottom bar	Exterior curtain-side guide	Interior curtain-side guide						
gray/tan/ wht/brn	•	•	slide bolt	•	•	•	•	•	•	•	•	•	•	•	•	•	•	•	
gray/tan/ wht/brn	•	•	slide bolt	•	•	•	•	•	•	•	•	•	•	•	•	•	•	•	
gray/tan/ wht/brn	•		slide bolt	•	•	•	•	•	•	•	•	•	•	•	•	•	•	•	
gray	•			•	•						•				•	•			
gray/tan/ wht/brn	•		slide bolt	•	•						•		•		•	•		•	
white-white brown-white white-brown			slide bolt	•	•						•		•			•			

Stormtite™ Insulated Heavy-Duty Rolling Service Doors

SERIES 625

Standard Features At a Glance

Max. standard width	30' (9144 mm)
Max. standard height	28' (8534 mm)
Curtain	24 ga. galvanized steel front 24 ga. galvanized steel back
Slat profile	Flat, insulated, type F-265i
Insulation	Foamed-in-place, CFC-free polyurethane 
R-value	7.7* (1.35 W/Msq)*
STC Rating	21
Finish	Gray, tan, brown or white
Hood	24 ga. galvanized steel
Wind load	20 psf
Standard mounting	Face of wall
Operation	Chain hoist
Standard springs	20,000 cycle
Weatherseals	Bottom, exterior curtain-side guide, interior hood baffle
Guides	Structural steel
Bottom bar	Primed steel with vinyl weatherseal
Lock	Chain keeper
Warranty	24-month limited

Options

- Electric operator (RHX®, RSX®, RMX®)
- Aluminum or stainless steel slats
- Bottom sensing edge
- Crank operation
- Between-jambs mounting
- High-usage package
- High-wind load option
- Weatherseal for interior side guide
- Lintel seal
- Bottom sensing edge
- Galvanized steel bottom bar angle guides
- Cylinder lock
- Pass doors
- Exhaust ports
- PowderGuard™ finish offers full spectrum of up to 215 colors as well as color matching to specification.

*If your project requires a higher R-value, ask your Overhead Door Red Ribbon Distributor about our Thermacore® door system, which offers R-values to 17.50 (3.09 W/Msq).

The Stormtite™ 625 Series is an insulated, heavy-duty rolling service door that is an ideal choice for applications requiring a moderate level of thermal protection.* Designed in sizes up to 30' wide and 28' high (9144 mm and 8534 mm), these doors are constructed with a CFC-free, foamed-in-place polyurethane insulation. Vinyl weatherstripping on the bottom bar, exterior curtainside guide and hood baffle provides additional protection against air infiltration.

Slat Data

F-265i Slat

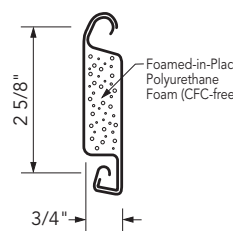

R-value 7.7* (1.35 W/Msq)*
 U-value .13
 Smoke Generation = 10
 Flame Spread = 5

Slat	Opening Width	Standard	Optional
F265I	Thru 30'4" (9246 mm)	24 ga.	22, 20, 18 ga. 22, 20 ga. ss .032 alum.

Slats are galvanized and painted, stainless steel (ss) (specify finish) or aluminum (specify finish).

Headroom Clearance Dimensions (some options may affect clearance dimensions.)

Dimension A F265i Slat

Opening Height	Max. Door Opening Widths			
	20'0" (6096 mm)	24'0" (7315 mm)	30'0" (9144 mm)	
Thru 6'0" (1829 mm)	16" (406 mm)	16" (406 mm)	18" (457 mm)	
Thru 8'0" (2438 mm)	18" (457 mm)	18" (457 mm)	20" (508 mm)	
Thru 9'0" (2743 mm)	18" (457 mm)	18" (457 mm)	20" (508 mm)	
Thru 11'0" (3353 mm)	20" (508 mm)	20" (508 mm)	22" (559 mm)	
Thru 13'0" (3962 mm)	20" (508 mm)	20" (508 mm)	22" (559 mm)	
Thru 16'0" (4877 mm)	22" (559 mm)	24" (610 mm)	24" (610 mm)	
Thru 18'0" (5486 mm)	24" (610 mm)	24" (610 mm)	26" (660 mm)	
Thru 21'0" (6401 mm)	24" (610 mm)	24" (610 mm)	26" (660 mm)	
Thru 23'0" (7010 mm)	26" (660 mm)	26" (660 mm)	26" (660 mm)	
Thru 25'0" (7620 mm)	28" (711 mm)	28" (711 mm)	28" (711 mm)	
Thru 28'0" (8534 mm)	30" (762 mm)	30" (762 mm)	30" (762 mm)	
Thru 30'0" (9144 mm)	30" (762 mm)	30" (762 mm)	30" (762 mm)	



Door Clearance Elevations

Face-of-Wall Mounted

Operation: Chain hoist or electric.

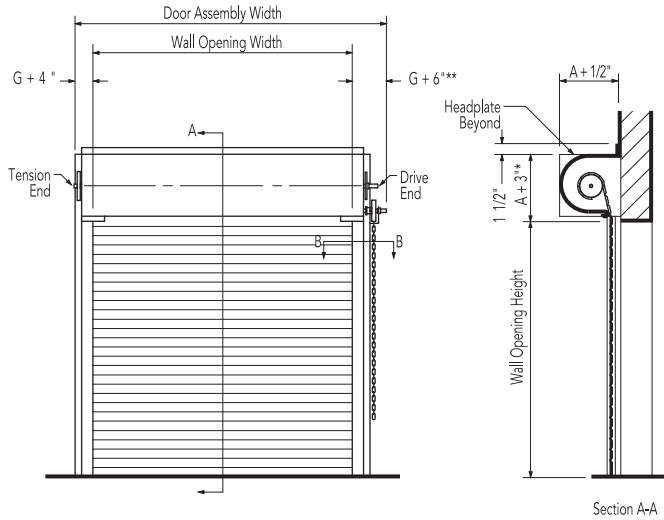

Between Jambs Mounted

Operation: Chain hoist or electric.

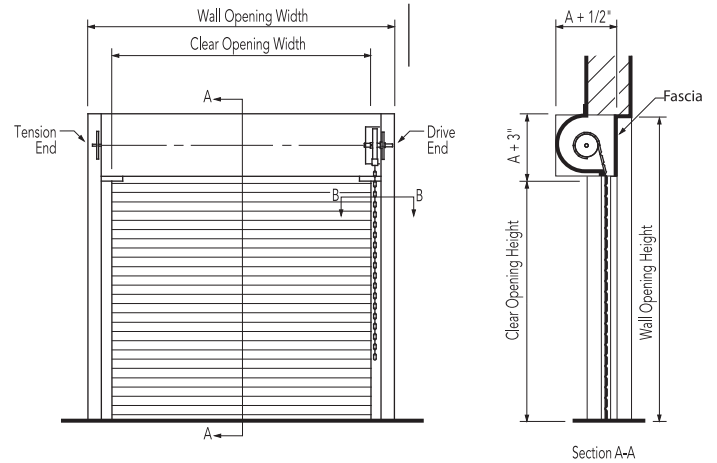

Angle Guides

Face-of-Wall Mounted

Section B-B

E Guide

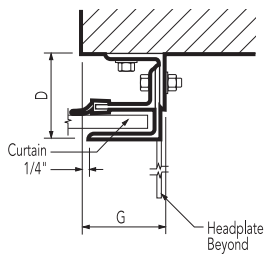

Z Guide

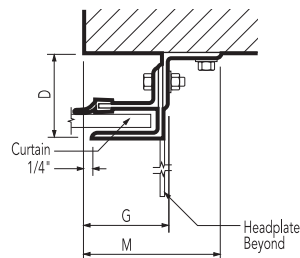

Between Jambs Mounted

Section B-B

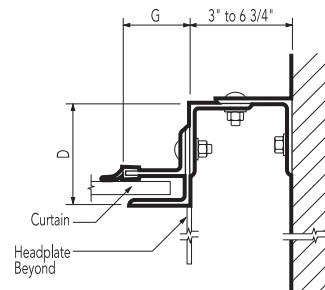

Dimensions G, M and D* F265i Slat

Dimensions Max Door Opening Widths		9'0"	15'0"	20'0"	30'0"	40'0"				
		(2743 mm)	(4572 mm)	(6096 mm)	(9144 mm)	(12,192 mm)				
G	3"	(76 mm)	3 1/2"	(89 mm)	4"	(102 mm)	4 1/2"	(114 mm)	5 5/8"	(144 mm)
M	5 1/4"	(133 mm)	5 3/4"	(146 mm)	6 3/4"	(171 mm)	8 1/4"	(210 mm)	4 1/2"	(210 mm)
D	4 1/2"	(114 mm)	5"	(127 mm)	5"	(127 mm)	6"	(152 mm)	6"	(152 mm)

Dimensions G and D* F265i Slat

Dimensions Max Door Opening Widths		9'0"	15'0"	20'0"	30'0"	40'0"				
		(2743 mm)	(4572 mm)	(6096 mm)	(9144 mm)	(12,192 mm)				
G	3"	(76 mm)	3 1/2"	(89 mm)	4"	(102 mm)	4 1/2"	(114 mm)	5 5/8"	(144 mm)
D	4 1/2"	(114 mm)	5"	(127 mm)	5"	(127 mm)	6"	(152 mm)	6"	(152 mm)

* For max. door opening height
Windbars included on doors over 14' (4267 mm) wide

* For max. door opening height
Windbars included on doors over 14' (4267 mm) wide

Stormtite™ Insulated Heavy-Duty Rolling Service Doors

SERIES 625



Standard Features At a Glance

Max. standard width	30' (9144 mm)
Max. standard height	28' (8534 mm)
Curtain	22 ga. galvanized steel up to 18'4" (5588 mm) width 20 ga. galvanized steel up to 25'4" (7722 mm) width 24 ga. galvanized steel up to 15'4" (4877 mm) width 18 ga. galvanized steel up to 30' (9144 mm) width
Slat profile	Curved, type C-187 (610 Series) Flat, type F-265 (620 Series)
Finish	Gray, tan, brown or white
Hood	24 ga. galvanized steel
Windload	20 psf
Standard mounting	Face of wall
Operation	Manual push-up up to 84 sq. ft. (7804 sq.mm) or 12' x 7' (3658 mm x 2134 mm) Chain hoist over 84 sq. ft. (7804 sq.mm) or 12' x 7' (3658 mm x 2134 mm)
Standard springs	20,000 cycle
Weatherseals	Bottom bar astragal (Series 610/620) Guides and hood baffle (Series 620)
Guides	Primed steel
Bottom bar	Extruded aluminum with weatherseal to 15'4" (4674 mm) Back-to-back steel angles with weatherseal > 15'4" (4674 mm)
Lock	Chain keepers on chain hoist
Warranty	24-month limited

Options

- Electric operator (RHX®, RSX®, RMX®)
- Bottom sensing edge
- Crank operation
- Between-jambs mounting
- Stainless steel or aluminum slats
- High-usage package
- High-wind load option
- Galvanized steel bottom bar angle guides
- Cylinder lock
- Pass doors
- Exhaust ports
- PowderGuard™ finish offers full spectrum of up to 215 colors as well as color matching to specification.

*If your project requires a higher R-value, ask your Overhead Door Red Ribbon Distributor about our Thermacore® door system, which offers R-values to 17.50 (3.09 W/Msq).

The 610 Series and Stormtite™ 620 Series are suitable for heavy-duty commercial applications. The 620 Series doors are similar to the 610 Series, but are furnished with weatherstripping on the exterior side of guides, on the bottom bar and in the hood baffle. Weatherseals for the interior side of guides or hood lintel are available as options. The Stormtite™ door system features a steel curtain with flat-profile slats. Aluminum and stainless steel slats are optionally available.

Slat Data

Series 610

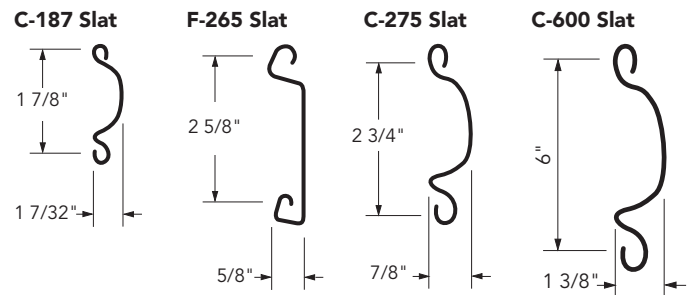

Slat	Opening Width	Standard	Optional
C187	Thru 15'4" (4674 mm)	22 ga.	24, 20, 18 ga. or 22, 20 ga. ss
C275	Thru 18'4" (5588 mm)	22 ga.	20, 18, 16 ga. or 22, 20 ga. ss
	Thru 25'4" (7722 mm)	20 ga.	18, 16 ga. or 20 ga. ss
	Thru 30'4" (9246 mm)	18 ga.	16 ga.
F265	Thru 18'4" (5588 mm)		22, 20, 18, 16 ga. or 20, 22 ga. ss
			14 ga. alum.
	Thru 25'4" (7722 mm)		20, 18, 16 ga. or 20 ga. ss
	Thru 30'4" (9246 mm)		18, 16 ga.
C600	Thru 70' (21,336 mm)	18 ga.	14 ga.

Slats are galvanized and painted or stainless steel (ss).

Series 610

F-265 Slat

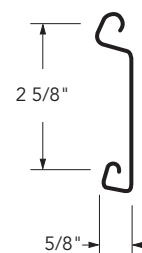

Slat	Opening Width	Standard	Optional
F265	Thru 18'4" (5588 mm)	22 ga.	20, 18, 16 ga. or 22, 20 ga. ss
			14 ga. alum.
	Thru 25'4" (7722 mm)	20 ga.	18, 16 ga. or 20 ga. ss
	Thru 30'4" (9246 mm)	18 ga.	16 ga.

Heavy-Duty and Stormtite™ Heavy-Duty Rolling Service Doors

SERIES 610 620

Door Clearance Elevation

Face-of-Wall Mounted

Operation: Chain hoist or electric.

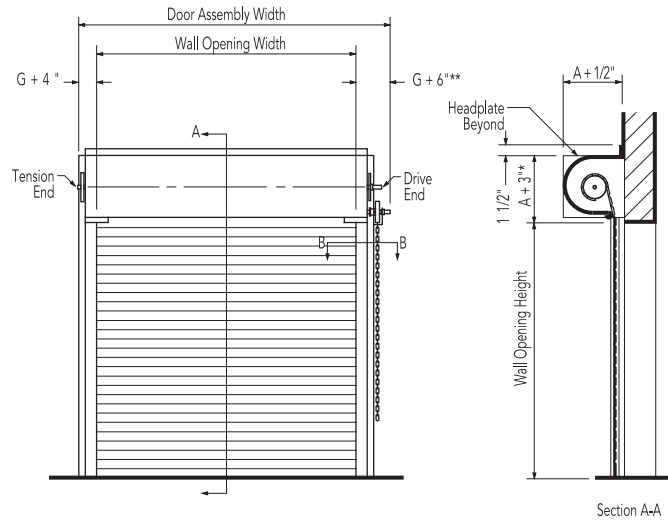

Between Jamb Mounted

Operation: Push-up, chain hoist, crank or electric.

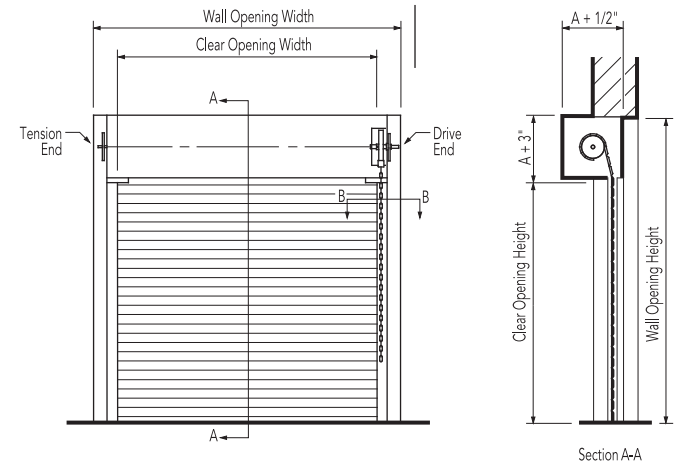

For clearance details on electrically operated doors, see Electric Operators pages 24.

Door Clearance Dimensions

Dimension A C187 Slat

(Series 610 only)

Opening Height	Max. Door Opening Widths	
	15'4" (4674 mm)	15'4" (4674 mm)
Thru 6'0" (1829 mm)	14" (356 mm)	15'4" (4674 mm)
Thru 11'0" (3353 mm)	14" (356 mm)	15'4" (4674 mm)
Thru 18'0" (5486 mm)	16" (356 mm)	15'4" (4674 mm)
Thru 21'0" (6401 mm)	18" (356 mm)	15'4" (4674 mm)
Thru 30'0" (9144 mm)	24" (356 mm)	15'4" (4674 mm)

Dimension A F265 Slat

Opening Height	Max. Door Opening Widths		
	20'0" (6096 mm)	24'0" (6096 mm)	30'0" (9144 mm)
Thru 6'0" (1829 mm)	16" (406 mm)	16" (406 mm)	18" (457 mm)
Thru 8'0" (2438 mm)	18" (457 mm)	18" (457 mm)	20" (508 mm)
Thru 9'0" (2743 mm)	18" (457 mm)	18" (457 mm)	20" (508 mm)
Thru 11'0" (3353 mm)	18" (457 mm)	18" (457 mm)	20" (508 mm)
Thru 13'0" (3962 mm)	20" (508 mm)	20" (508 mm)	20" (508 mm)
Thru 16'0" (4877 mm)	20" (508 mm)	20" (508 mm)	22" (559 mm)
Thru 18'0" (5486 mm)	20" (508 mm)	22" (559 mm)	24" (610 mm)
Thru 21'0" (6401 mm)	22" (559 mm)	24" (610 mm)	24" (610 mm)
Thru 23'0" (7010 mm)	22" (559 mm)	24" (610 mm)	24" (610 mm)
Thru 25'0" (7620 mm)	24" (610 mm)	24" (610 mm)	26" (660 mm)
Thru 28'0" (8534 mm)	26" (660 mm)	26" (660 mm)	26" (660 mm)
Thru 30'0" (9144 mm)	26" (660 mm)	26" (660 mm)	28" (711 mm)

Dimension A C275 Slat (Series 610 only)

Opening Height	Max. Door Opening Widths		
	20'0" (6096 mm)	24'0" (6096 mm)	30'0" (9144 mm)
Thru 6'0" (1829 mm)	14" (356 mm)	14" (406 mm)	18" (457 mm)
Thru 8'0" (2438 mm)	16" (406 mm)	16" (406 mm)	18" (457 mm)
Thru 9'0" (2743 mm)	16" (406 mm)	18" (457 mm)	20" (508 mm)
Thru 11'0" (3353 mm)	16" (406 mm)	18" (457 mm)	20" (508 mm)
Thru 13'0" (3962 mm)	18" (457 mm)	18" (457 mm)	20" (508 mm)
Thru 16'0" (4877 mm)	18" (457 mm)	20" (508 mm)	22" (559 mm)
Thru 18'0" (5486 mm)	20" (508 mm)	22" (559 mm)	24" (610 mm)
Thru 21'0" (6401 mm)	22" (559 mm)	22" (559 mm)	24" (610 mm)
Thru 23'0" (7010 mm)	22" (559 mm)	24" (610 mm)	24" (610 mm)
Thru 25'0" (7620 mm)	24" (610 mm)	24" (610 mm)	26" (660 mm)
Thru 28'0" (8534 mm)	26" (660 mm)	24" (610 mm)	26" (660 mm)
Thru 30'0" (9144 mm)	26" (660 mm)	26" (660 mm)	28" (711 mm)



Angle Guide

Face-of-Wall Mounted

Section B-B

E Guide

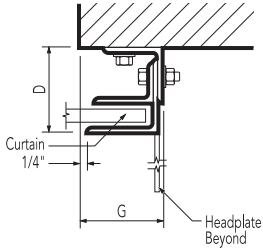

Z Guide

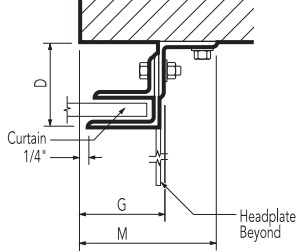

Between Jambs Mounted

Section B-B

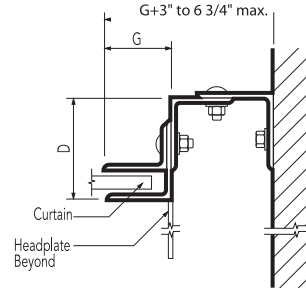

Dimensions G, M and D* C187 Slats

Dimensions	Max. Door Opening Width					
	8'0"	(2438 mm)	15'0"	(4572 mm)	20'0"	(6096 mm)
G	3"	(76 mm)	3 1/2"	(89 mm)	4"	(102 mm)
M	4 3/4"	(121 mm)	5 1/4"	(133 mm)	5 3/4"	(146 mm)
D	4 1/2"	(114 mm)	4 1/2"	(114 mm)	5"	(127 mm)

Dimensions G and D* C275 and F265 Slats

Dimensions	Max. Door Opening Width									
	9'0"	(2743 mm)	15'0"	(4572 mm)	20'0"	(6096 mm)	30'0"	(9144 mm)	40'0"	(12,192 mm)
G	3"	(76 mm)	3 1/2"	(89 mm)	4"	(102 mm)	4 1/2"	(114 mm)	5 5/8"	(144 mm)
D	4 1/2"	(114 mm)	5"	(127 mm)	5"	(127 mm)	6"	(152 mm)	6"	(152 mm)

Dimensions G, M and D* C275 and F265 Slats

Dimensions	Max. Door Opening Width									
	9'0"	(2743 mm)	15'0"	(4572 mm)	20'0"	(6096 mm)	30'0"	(9144 mm)	40'0"	(12,192 mm)
G	3"	(76 mm)	3 1/2"	(89 mm)	4"	(102 mm)	4 1/2"	(114 mm)	5 5/8"	(144 mm)
M	4 3/4"	(121 mm)	5 1/4"	(133 mm)	5 3/4"	(146 mm)	8 1/4"	(210 mm)	8 1/4"	(210 mm)
D	4 1/2"	(114 mm)	4 1/2"	(114 mm)	5"	(127 mm)	6"	(152 mm)	6"	(152 mm)

* For max. door opening height

Note: Windbars provided for doors over 15' 4" (4674 mm)

Series 620 guides include weatherstrip on exterior side of door.

Heavy-Duty and Stormtite™ Heavy-Duty Rolling Service Doors

SERIES 610 620

Installation and Service: Overhead Door Company of Longview





For drawings and specifications please access our electronic Architectural Design Manual at <http://www.OverheadDoor.com/ADM/base.html>

Installation and Service: Overhead Door Company of Fort Worth



Special Application Doors

Overhead Door Corporation manufactures rolling steel service doors for unique specifications or circumstances. Designers and builders rely on our knowledge, expertise, quality and workmanship for a variety of special application doors—including those that allow access for cranes or pedestrians, oversized doors for railroad cars or aircraft, high-usage doors for heavy-traffic openings, and combination doors for air and light infiltration. Whatever your functional requirements or aesthetic considerations are, your local Overhead Door Red Ribbon Distributor will work directly with you to computer-customize a door that fits and lasts.

High-Usage Doors

A special high-usage package provides an array of rugged quality component assemblies to ensure reliable, long-term performance for high traffic areas, such as parking garages, vehicle maintenance bays, and high-volume loading dock areas. The package includes a choice of higher-cycle springs. These springs convert any of Overhead Door Corporation's rolling steel service doors from a standard 20,000-cycle spring (appropriate for doors subjected to 10 cycles per day) to 50,000, 75,000 or 100,000-cycle springs for heavy usage of 100 cycles or more per day. The high-usage package also includes heavy-duty bearings and wear strips inside guides. Available on 610, 620 and 625 Series doors.

Oversized Doors

Overhead Door Corporation offers large doors in sizes up to 1500 square feet (139,355 sq. mm)**, for applications ranging from aircraft hangars to railway loading sheds. These doors feature the C-600 slat (standard in 18 ga., optional 16 ga. and 14 ga.), a 6" (152 mm), 1-3/8" (35 mm) curved slat that is built for durability in heavy-duty industrial and commercial environments. Available on 610 Series doors.

Craneway Doors

Craneway doors are especially convenient in warehouses and work areas where large industrial equipment is used or stored. These T-shaped doors incorporate a curtain design that allows overhead clearance for the crane apparatus in addition to the standard door opening. Available on 610, 620 and 625 Series doors.

Pedestrian Pass Doors

ADA-compliant pass doors provide a means of passage for pedestrian traffic without raising the rolling door. Available on 610, 620 and 625 Series doors.

Ventilated Doors with perforated or fenestrated slats restrict unauthorized entry while allowing visual access and air circulation. Perforations are 1/16" (2 mm) diameter holes on 3/32" (2 mm) centers and are available in both flat (F-265) and curved (C-275) slat profiles.* Available on 610 Series doors.

Fenestrated service doors are ideal for applications where ventilation and/or light transference are important. Flat (F-265) or curved (C-275) slats have uniformly spaced openings of 5/8" x 3" (16 mm x 76 mm) for maximum air flow. Fenestrated service doors can also be designed with plexiglas to provide full visual access without air infiltration. Available on 610 Series doors.

Combination Doors

Overhead Door Corporation can custom design combination doors to fit unique situations and unusual applications. The most common combination door is a grille mounted on a rolling steel door to provide security while also permitting free air flow and/or visual access when desired. The grille option is available on 610, 620 and 625 Series doors. Other types of combination doors include a door-on-door, such as a perforated door mounted on a standard rolling door. A single-curtained door fabricated of two or more slat styles and configurations allows customization to unusual requirements. These doors may combine standard slats, fenestrated and/or perforated slats, and/or a grille in a single curtain design. With virtually endless combinations available for your project, your Overhead Door Red Ribbon Distributor is an important resource for information and design assistance.

Spark-Resistant Doors

Used in conjunction with explosion-proof electric operators, Overhead Door Corporation's spark-resistant doors offer an added measure of safety in volatile environments. Common applications include grain elevators, chemical plants and paint spray booths. Available on 610, 620 and 625 Series doors.

High Wind Load Doors

Overhead Door Corporation designs doors for high wind load conditions to withstand wind loading well in excess of our standard 20 psf capacity. Doors are computer-designed and built to meet stringent wind load standards, such as those required by Metro/Dade County building codes. Ask your Overhead Door Red Ribbon Distributor for details. Available on 600, 610, 620 and 625 Series doors.

Bottom Sloping Bars

The 610, 620 and 625 Series doors are available with a sloping bottom bar to accommodate unlevel or sloping conditions. Ask your Overhead Door Red Ribbon Distributor for details.

Advanced Service Doors

Overhead Door Corporation manufactures a product line of Advanced Service Doors that offer increased speed, security and durability. Ask your Overhead Door Red Ribbon Distributor for more information about these doors.

*Refer to page 3 for more information about slat profiles and color options.

**Consult factory for even larger openings



Special Applications Door Clearance Elevations

Crane Door
Interior Elevation

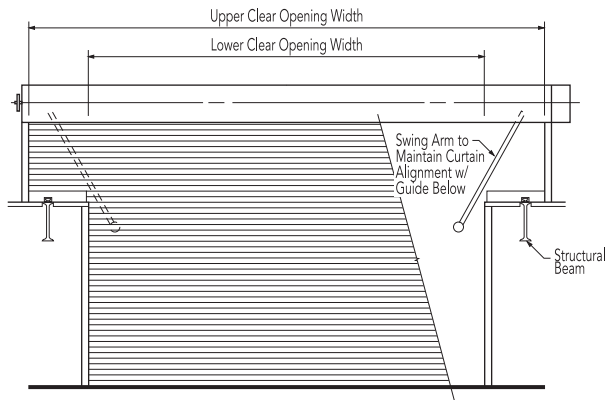

Ventilated Service Doors
Interior Elevation (Fenestrated Door)

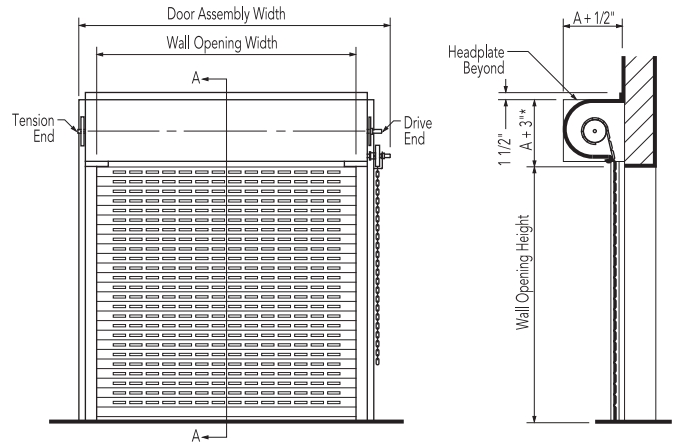

Note: See 610 Series for applicable headroom and guide clearance details and dimensions.

Combination Door & Grille
Door Clearance Elevations

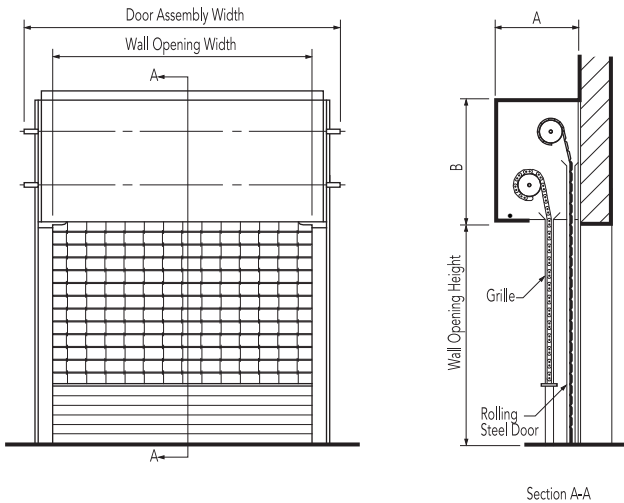

Service Door With Pedestrian Pass Door
Interior Elevation ("Swing - In")

Overhead Door Corporation pedestrian pass doors installed on rolling service doors are ADA accessible.

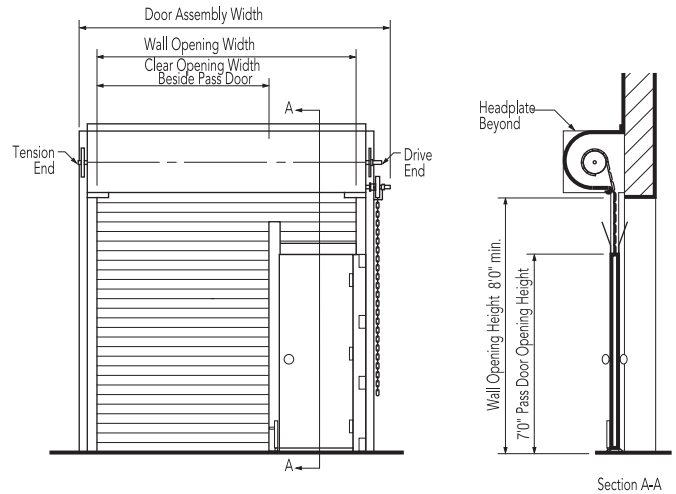

Special Application Slat Data

Fenestrated Door

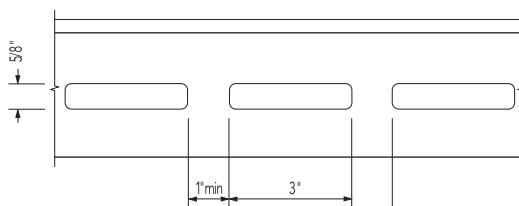

Perforated Door

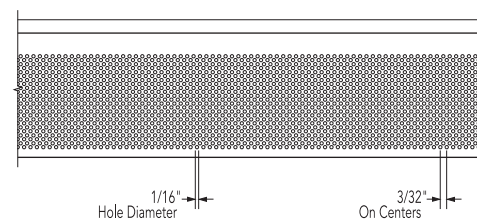

Coil-Away™ Light-Duty Rolling Service Doors

SERIES 600

Standard Features At a Glance

Max. standard width	16' (4877 mm)
Max. standard height	16' (4877 mm)
Curtain	26 ga. galvanized steel up to 12'4" (3759 mm) width 24 ga. galvanized steel up to 14' (4267 mm) width
Slat profile	Flat crown profile type CAW
Finish (interior/exterior)	White/white, white/brown, brown/white
Standard mounting	Face of wall
Counterbalance	High tensile helical torsion spring housed in a steel tube or pipe barrel assembly.
Brackets	Galvanized steel to support counterbalance and curtain.
Operation	Manual push-up up to 100 sq. ft. (9290 sq.mm) or 10' x 10' (3048 mm x 3048 mm) Chain hoist over 100 sq. ft. (9290 sq.mm) or 10' x 10' (3048 mm x 3048 mm)
Standard springs	20,000 cycle
Weatherseals	Bottom
Guides	Galvanized steel roll-formed shapes
Bottom bar	Extruded aluminum with weatherseal
Lock	Interior slide bolt
Warranty	24-month limited

Options

- Electric operator
- Bottom sensing edge
- Hood
- Wind load package
- Galvanized steel endlocks
- Between jambs
- PowderGuard™ finish offers full spectrum of up to 215 colors as well as color matching to specification.

The Coil-Away™ 600 Series rolling steel service door is an ideal choice where economy and functionality are important. The 600 Series offers a flat slat profile with weatherseals on the bottom. Designed in sizes up to 16' wide and 16' high (4877 mm and 4877 mm), the 600 Series is available with weatherstripping, wind load and motor operation options to expand its uses in a variety of light commercial applications.

Slat Data

CAW Slat

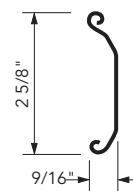

Slat	Opening Width	Standard	Optional
CAW	Thru 12'4" (3759 mm)	26 ga.	24 ga.
	Thru 16'0" (4877 mm)	24 ga.	

Slats are galvanized and painted.

Door Clearance Dimensions

Dimensions A and B CAW Slat

Opening Height		Opening Widths Thru 16'0" (4877 mm)			
		A		B	
Thru 11'0"	(3353 mm)	13"	(330 mm)	18"	(381 mm)
Thru 16'0"	(4877 mm)	15"	(381 mm)	18"	(457 mm)

Dimensions A and B With optional hood and CAW Slat

Opening Height		Opening Widths Thru 16'0" (4877 mm)			
		A		B	
Thru 16'0"	(4877 mm)	15"	(381 mm)	18"	(457 mm)



Door Clearance Elevations

Face-of-Wall Mounted

Operation: Push-up, chain hoist or electric.

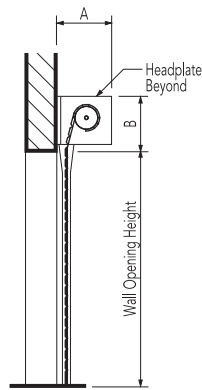
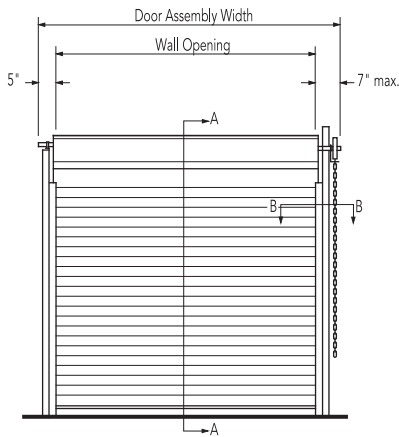

Section A-A

Face-of-Wall Mounted (with hood)

Operation: Push-up, chain hoist or electric.

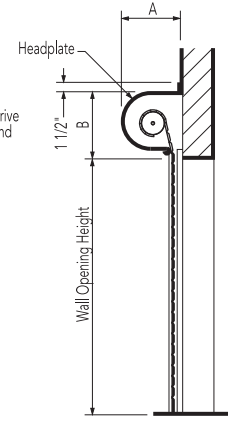
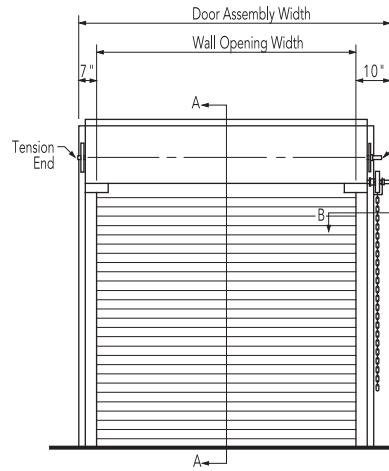

Section A-A

For clearance details on electrically operated doors, see Electric Operators pages 17.

Rolled Guides

Face-of-Wall Mounted

Section B-B

E Guide

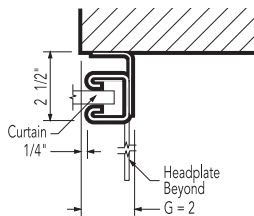

Z Guide

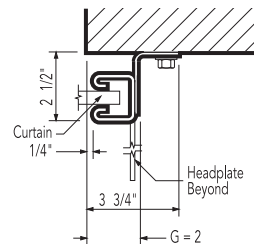

Steel Buildings

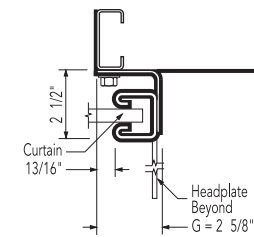

* Guide angle welded to steel jamb.

Operator Control Options

- Push-button, key or combination stations; surface or flush-mounted for interior and/or exterior locations
- Vehicle detectors, key card reader, photocell and door timer controls
- Treadle or pull switch stations
- Telephone entry and coded keyboard stations
- Universal programmable door timer
- Commercial light package
- Radio control systems (24 VAC or 120 VAC)
- Explosion and dust ignition-proof systems

Electric Operator Selection Guide

	Horsepower	Max. height of door	Max. weight of door	Superbelt™	Worm gear	Adjustable clutch	Totally enclosed	Continuous duty	Mounting type
Model RMX®	1/2 HP	14' (4267 mm)	646 lbs (293 kg)	•					B,F,T,W
Model RSX®	1/2, 3/4, 1 HP	N/A	1196 lbs (540kg)	•		•	•	•	B,F,T,W
Model RHX®	1/2, 3/4, 1, 3 HP	N/A	3696 lbs (1676 kg)		•	•	•	•	B,F,T,W

Mounting Options: F = Front of Hood, B = Bench Mount,
W = Wall Mount, T = Top of Hood
* Maximum area in square feet (square millimeters).

Safety Recommendations

Overhead Door Corporation strongly recommends the use of interlock switches and an electric safety edge for all electrically operated rolling service doors. If a sensing edge or other reversing device is not installed, a constant-contact control switch must be used to close the door. We recommend a self-mounting, four-wire, fail-safe electric sensing device. Contact your Overhead Door Red Ribbon Distributor for more information.

Overhead Door Corporation offers the broadest line of electric operators to suit new construction and retrofit applications, as well as unusual or special requirements. Manufactured by Overhead Door Corporation to meet the exacting performance requirements of Overhead Door's upward-acting doors, our ribbon branded operators afford precise control of door action for years of trouble-free operation.

In order to improve safety and enhance door and motor life, industry quality assurance guidelines recommend the choice of a single manufacturer for both door and operator applications. Overhead Door Corporation is the only national manufacturer of a full line of commercial and industrial doors and operators specifically designed for integrated applications.

Operator Models

Model RMX®

Model RMX® is an advanced medium-duty operator. It is designed for quicker installation and hassle-free operation and operates doors up to 14' (4267 mm) in height and 620 pounds (282 kg). It is available as a trolley-type or side-mounted unit.



Model RSX®

Model RSX® is a standard duty commercial operator designed to operate doors up to 24' (7315 mm) in height and 1450 pounds (657 kg) in weight. It offers unique features like LimitLock™, SuperBelt™, dual frequency radio system and 16 digit menu setup.



Model RHX®

Model RHX® is a heavy duty motor featuring industrial worm gear in oil bath design. The RHX® can operate doors up to 24' (7315 mm) in height and 1650 pounds (748 kg) in weight. It offers unique features like LimitLock™, dual frequency radio system and 16 digit menu setup.





Mounting Details

Front-of-Hood Mounted-RHX®

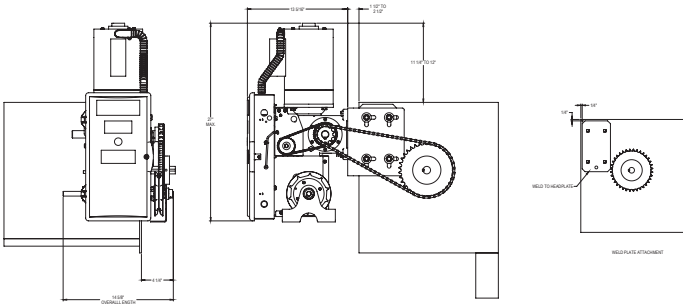

Front-of-Hood Mounted*-RSX®

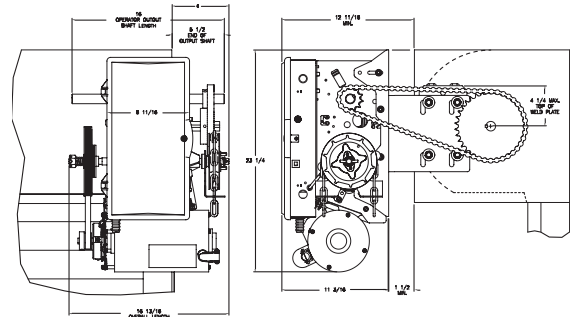

Top-of-Hood Mounted -RHX®

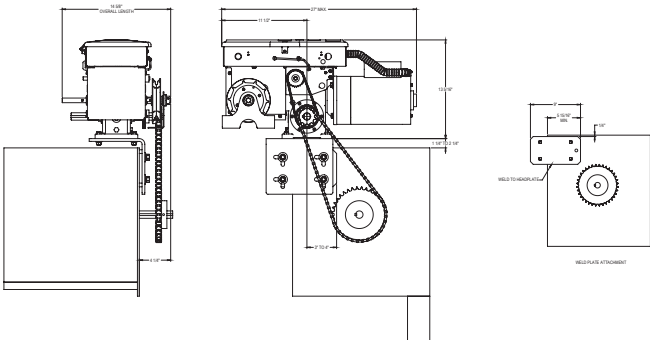

Top-of-Hood-RSX®

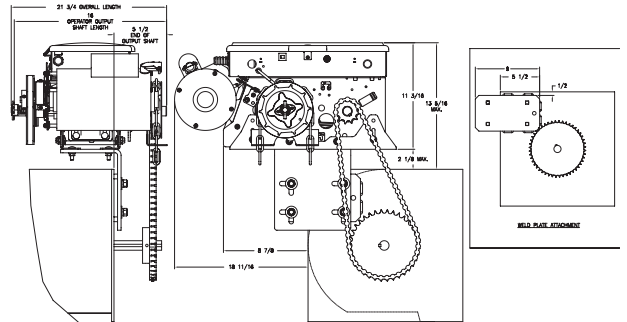

Wall Mounted (Below Shaft)-RHX®

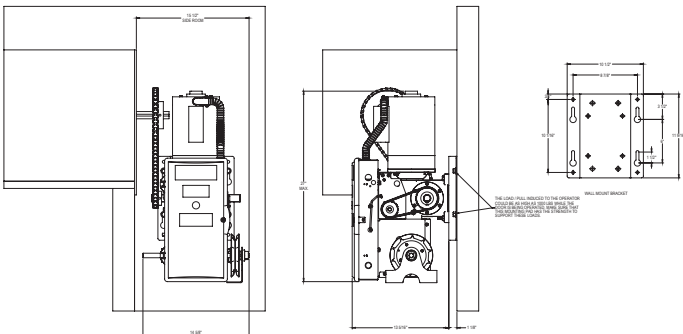

Wall Mount-RSX®

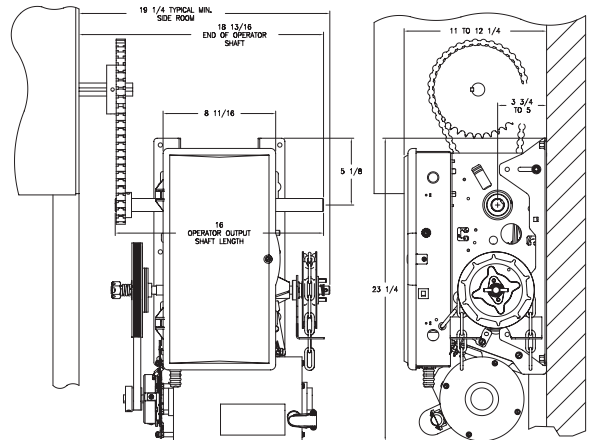

Note: For "A" and "G" dimensions, refer to Headroom and Guide Clearance Dimension charts applicable to door type selected.

* Front-of-Hood mounted also available on between jambs mounted doors.

For more detailed information, refer to the Overhead Door Corporation's Architectural Design Manual, or consult your local Overhead Door Distributor.

The Original, Innovative Choice for Unequaled Quality and Service

Overhead Door Corporation pioneered the upward-acting door industry, inventing the first upward-acting door in 1921 and the first electric door operator in 1926. Today, we continue to be the industry leader through the strength of our product innovation, superior craftsmanship and outstanding customer support, underscoring a legacy of quality, expertise and integrity. That's why design and construction professionals specify Overhead Door Corporation products more often than any other brand.

The Overhead Door Red Ribbon is a mark of quality that also reflects the pride we take in the people who support our products. Our family of over 400 Red Ribbon Distributors across the country not only share our name and logo, but also our commitment to excellence. Your Red Ribbon Distributor will work with you in a consultative role to ensure that product selections achieve your design and application requirements — in addition to offering expert installation, professional field service and ongoing maintenance. From project design and manufacturing to installation and service, the Overhead Door Red Ribbon is your guarantee of genuine quality and turnkey service excellence.

Together with our Red Ribbon Distributors, we offer comprehensive technical information and resource materials to support your project, including:

- Architectural Design Manual – a comprehensive guide to selecting, specifying and detailing all commercial and industrial Overhead Door products can be found at www.OverheadDoor.com/ADM/base.html
- Operation & Maintenance Manual – detailed product information, customized for your project, to ensure reliable, long-life door system operation
- Custom application and technical assistance through ordering plants' customer service and technical services respectively
- Visit our Architect's Corner at www.OverheadDoor.com



Advanced Rolling Steel Door
RapidSlat®



Thermacore® Sectional Doors



Rolling & Side Folding
Security Grilles & Closures



Rolling Service Doors



Commercial Operators

Today, Overhead Door Corporation – along with our Horton Automatics division, for automated pedestrian entrances – is recognized as the leading, single-source manufacturer of integrated door and operator systems for commercial, industrial and residential applications. With multiple manufacturing locations throughout the United States, a state-of-the-art TREQ (Testing, Reliability, Engineering, and Quality) Center for design and engineering, and a national network of authorized Red Ribbon Distributors, our capabilities are leading-edge and our field service and technical support second to none. Built best and backed best, Overhead Door is the industry's leading choice for quality that shows and lasts.

To talk with the Overhead Door distributor nearest you, call 1-800-929-DOOR.

Overhead Door Corporation

2501 S. State Hwy. 121 Bus., Suite 200

Lewisville, Texas 75067

1-800-929-DOOR

www.OverheadDoor.com



INDUSTRY LEADING
COMMERCIAL & INDUSTRIAL SOLUTIONS

The Overhead Door Corporation family of quality commercial and industrial products includes:



A part of Sanwa Holdings Corporation